



# ENVIROFLEX®

International Inc.

FOR A HEALTHIER WORK ENVIRONMENT

## PORTABLE AIR CLEANER

### ENVIROMAC™

## PORTABLE WELDING SMOKE EXTRACTOR



The ENVIROMAC™ Portable Welding Smoke Extractor is ideal for portable and fixed welding, dust and oil mist applications.

The unit comes standard with a high efficient washable filter and activated carbon in both doors. You utilize a precoat powder (Envirocoat) to maximize the filtration efficiency and prolong the life expectancy of the filter. The high efficient washable filter can be cleaned with an air hose or a pressure washer. There is also an optional throwaway paper filter.

The unit comes standard with the Snorkvac™ Fume Extractor Snorkel Arm which is 10ft.(3M) long and 6" (160MM) wide. The Snorkvac™ Fume Arm is externally supported to minimize the restriction to the air flow (pressure drop). It also makes arm adjustments or hose replacements much easier than an internally supported arm. The Fume Arm has a handle at the hood plus an additional handle on the first tube. The hood has an air diverter in it to increase the face velocity thus increasing the capture distance. The air diverter also gives you uniform air flow.

The units have 25 ft. of primary cable. The MAC1 runs off a 120 volt, 20 amp service outlet. The MAC2 runs off a 120 volt, 15 amp service outlet. The motors have thermal overload protection on the actual

motor. There is also a stand alone adjustable contactor overload which is located behind the Electrical Control Panel. This maximizes the protection to the motor. The top panel (Electrical Control Panel) of the machine allows easy access to the electrical components.

The units are manufactured out of 14 gauge cold rolled steel and painted with a baked on powder coat. The unit has (2) 4" fixed casters and (2) 4" rotating casters with a brake.

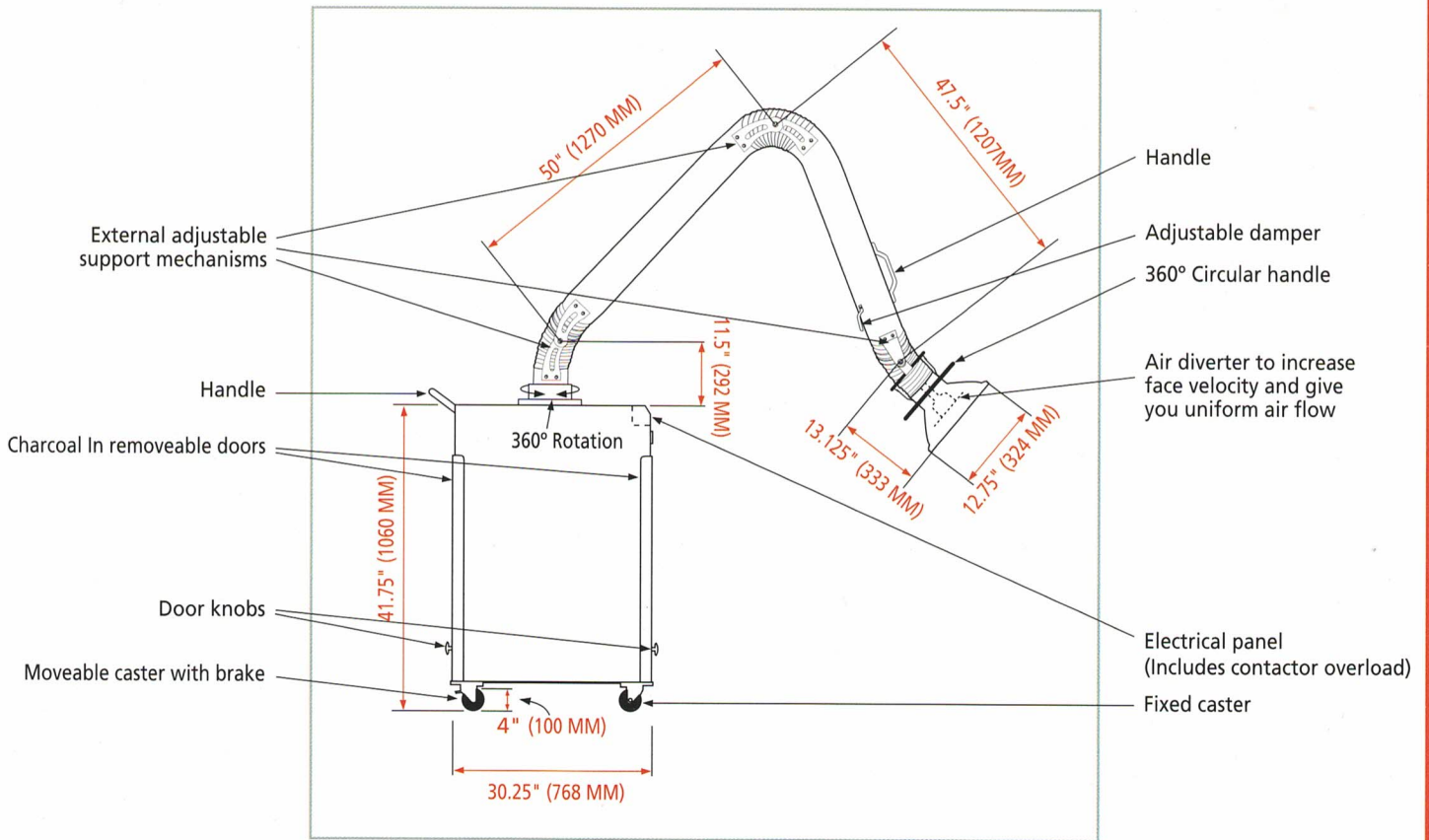

Model	MAC 1	MAC 2
<b>Voltage</b>	120 Volts, 50/60 HZ	120 Volts, 50/60 HZ
<b>Amperage</b>	17.5 amps	12 amps
<b>Motor(HP)</b>	1.5 HP	1 HP
<b>Motor RPM</b>	3450	3450
<b>Motor Type</b>	Direct drive, TEFC	Direct drive, TEFC
<b>Air Flow(at the hood)</b>	1400 CFM (2379 m3/hr)	1050 CFM (1784m3/hr)
<b>Arm Length</b>	10 ft. (3M)	10 ft. (3M)
<b>Arm Diameter</b>	6" (160 MM)	6" (160 MM)
<b>Dimensions</b>	Height = 41.75" (1060 MM)	Height = 41.75" (1060 MM)
	Width = 26" (660 MM)	Width = 26" (660 MM)
	Depth = 30.25" (768 MM)	Depth = 30.25" (768 MM)
<b>Weight(includes arm)</b>	290 lbs. (132 KGS)	288 lbs. (131 KGS)



IN USA

Enviroflex International Inc.  
1051 Clinton Street,  
Buffalo N.Y. 14206-2823

Phone: 716-883-2319 • Fax: 716-892-2139

DISTRIBUTOR

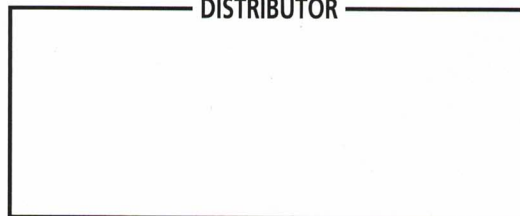

IN CANADA

Enviroflex International Inc.  
75 Rosedale Ave. W., Unit #12,  
Brampton Ont. L6X 4H4

Phone: 905-866-5606 • Fax: 905-866-5602

Enviroflex warrants all Air Cleaning products and systems for parts and workmanship for a period of one year from date of original purchase. This warranty does not apply to products subjected to any accident, alteration, abuse or misuse. Warranties on equipment not of seller's manufacture are limited to terms of warranty furnished by seller's suppliers. All specifications are subject to change without notice. Product may not be exactly as illustrated.

TOLL FREE: 1-877-ENV-FLEX (1-877-368-3539) • WEB: [www.enviroflex.com](http://www.enviroflex.com) • EMAIL: [info@enviroflex.com](mailto:info@enviroflex.com)